

ACTIVE INFRARED DETECTOR USAGE MANUAL

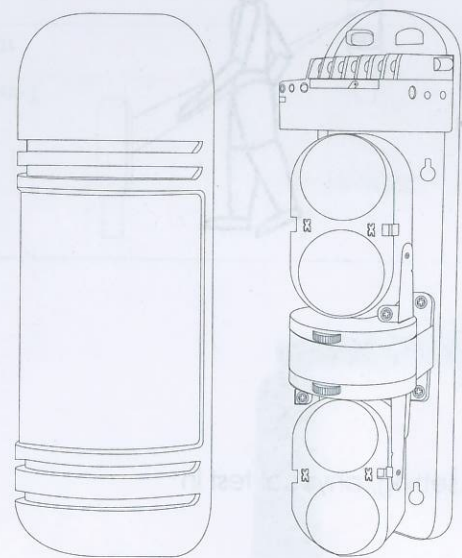

Model:

- 50L (Outdoor 50m, Indoor 150m)**
- 100L (Outdoor 100m, Indoor 300m)**
- 150L (Outdoor 150m, Indoor 450m)**
- 200L (Outdoor 200m, Indoor 600m)**
- 250L (Outdoor 250m, Indoor 750m)**

I. Part Name

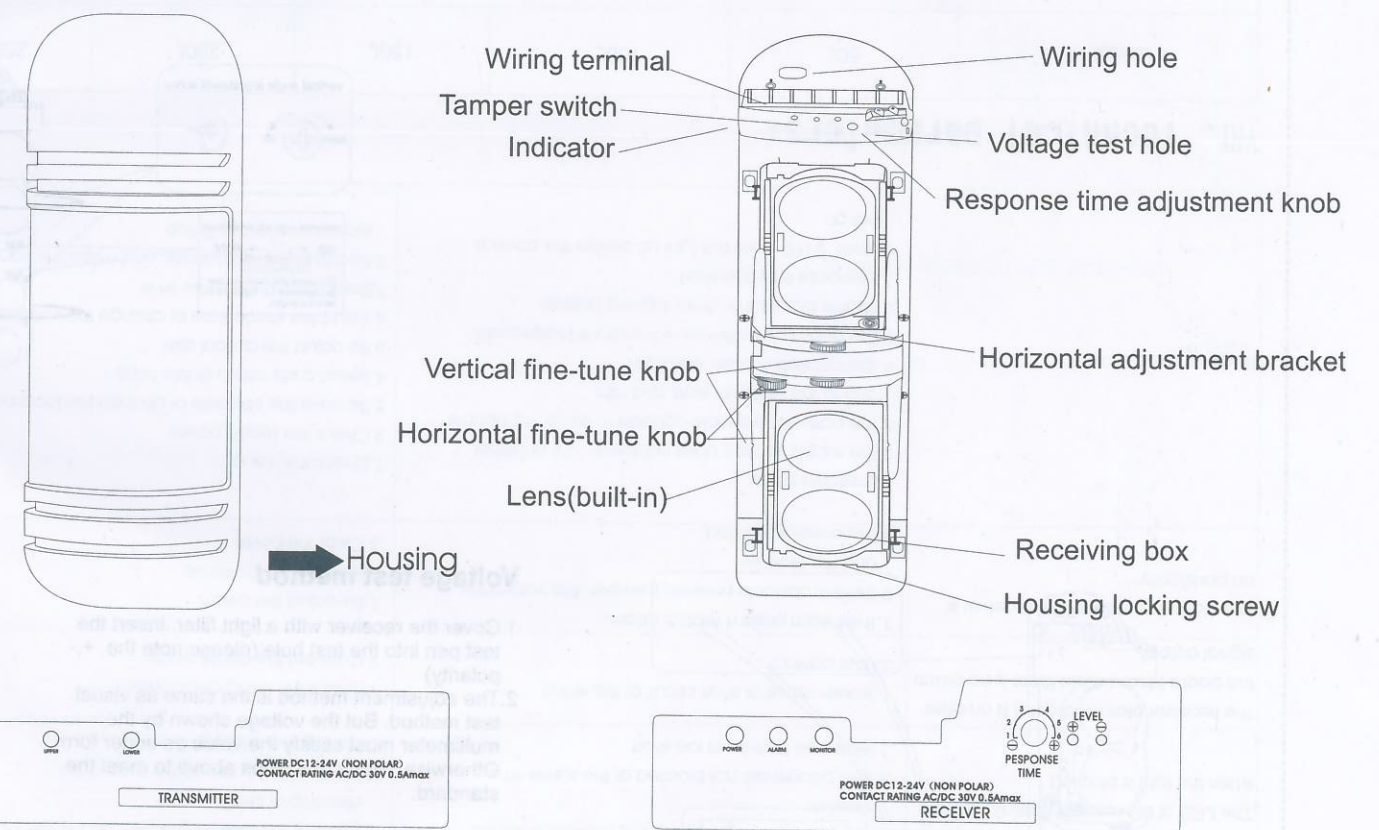

- UPPER indicator turns on when upper beam transmits.
- LOWER indicator turns on when lower beam transmits.

- POWER: The indicator turns on when power is connected.
- ALARM: The indicator turns on when alarm presents.
- MONITOR: (adjustment indicator) The green indicator turns on when the beam aligns with the receiver. If fails to align, the red indicator will on.

II. Precautions for setting

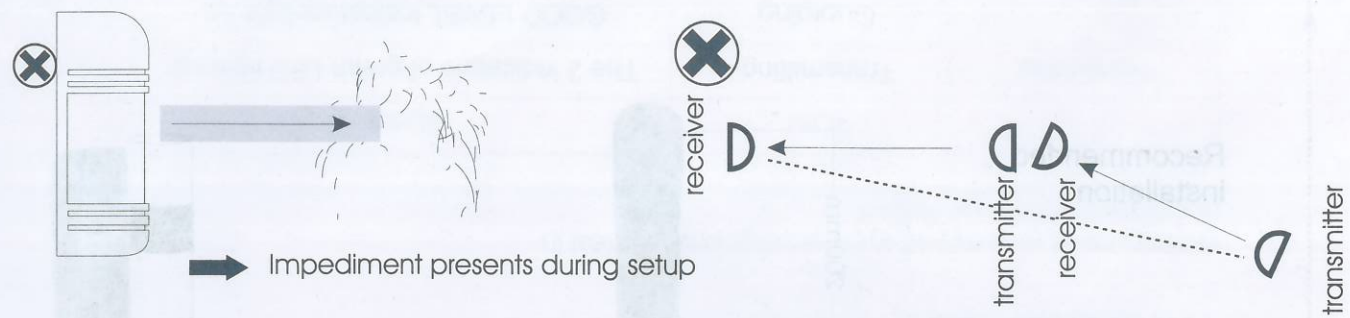

Impediment presents during setup

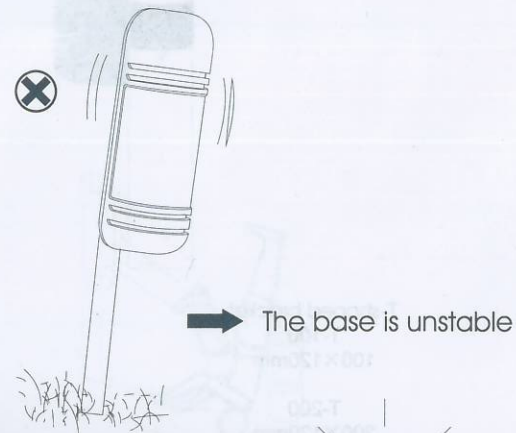

The base is unstable

Direct sunlight, lamplight etc.

Multi sensors may be used for long-distance guarding. Please install according to the below diagram to avoid interference between beams.

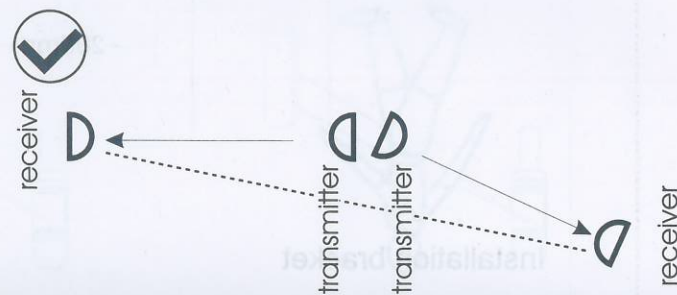

Adjustable angle: horizontal $\pm 90^\circ$
vertical $\pm 10^\circ$

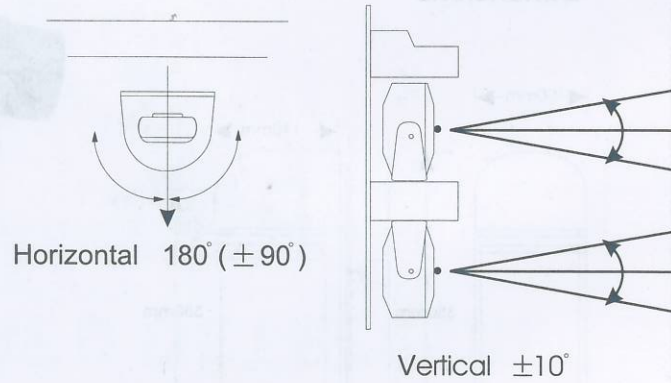

Horizontal $180^\circ (\pm 90^\circ)$

Vertical $\pm 10^\circ$

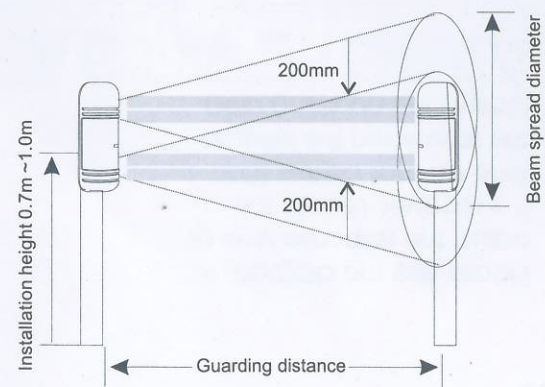

Model	Guarding distance	Beam spread diameter
50L	50m	0.8m
100L	100m	1.6m
150L	150m	2.4m
200L	200m	3.2m
250L	250m	4.0m

III Setting procedure

1. Remove the cover

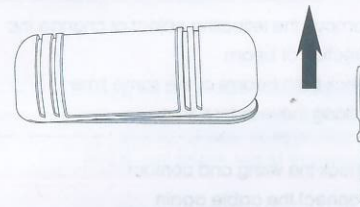

Installation of fixed bracket

1. Drill a hole on the bracket and extend out the cable from it.

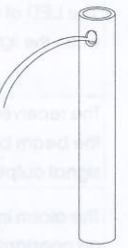

2. Remove the cover.

2. Put the cable through the hole for wiring.

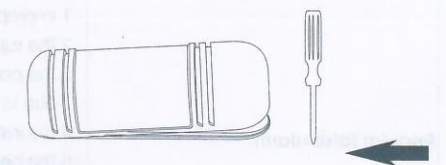
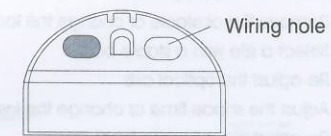

3. Fasten the base-plate to the bracket.

3. Fix the main body onto the wall

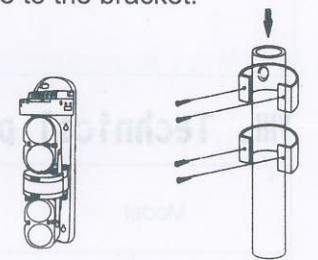
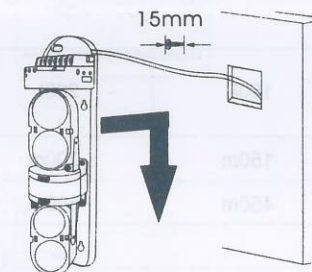

(Back-to-back installation guiding diagram)

4. Connect the cable to the Wiring terminal.

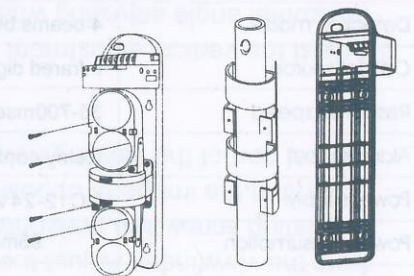
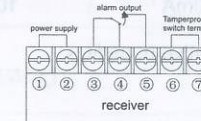
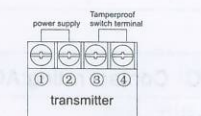
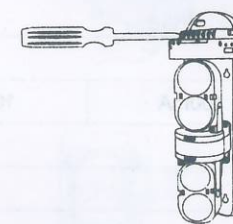

5. Put on the cover after adjusting the response time of the beam.

The line distributing distance from the sensor body to the sign accept implement

wire size	distance	voltage	
		DC12V	DC24V
0.5mm ² (0.8)		300m	300m
0.75mm ² (1.0)		400m	800m
1.25mm ² (1.2)		700m	1400m
2.0mm ² (1.6)		1000m	2000m

IV Beam alignment

Visual test method

1. Remove the cover and connect power.
2. Observe the collimation effect at a distance of 5cm from the viewfinder. Adjust the upper / lower angle regulation screw and horizontal adjustment wheel in order that the image of opposite detector falls into the central part of the viewing hole.
3. Adjust the vertical adjustment screw and the horizontal angle adjusting wheel, the signal strength indicator will light up step by step, adjust until level 5 or higher indicator lights up. If not, adjust it repeatedly.

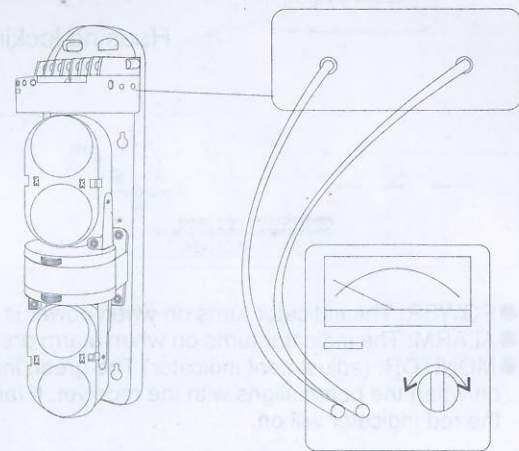
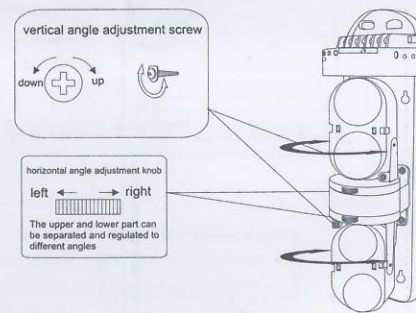
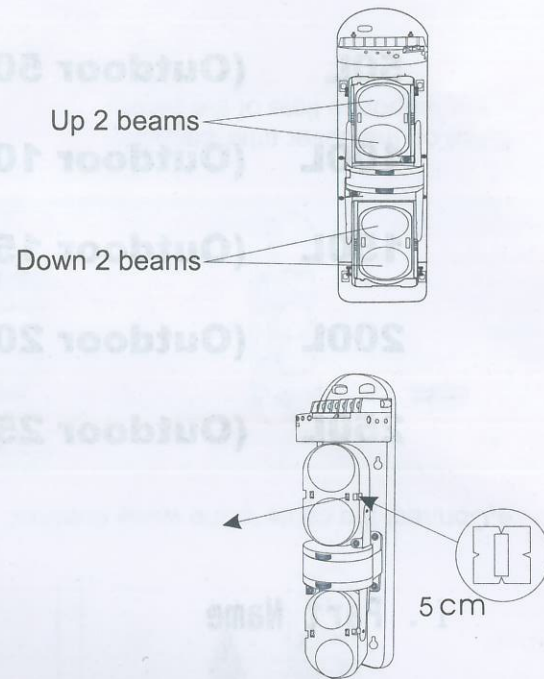

Multimeter selects DC 10V

Voltage test method

1. Cover the receiver with a light filter. Insert the test pen into the test hole (please note the +, - polarity)
2. The adjustment method is the same as visual test method. But the voltage shown by the multimeter must satisfy the value as under form. Otherwise, repeat the steps above to meet the standard.

MODEL	VOLTAGE
50L/100L	DC1.4~1.5V
150L/200L	DC1.4~1.5V
250L	DC1.2~1.3V

V Beam response time adjustment

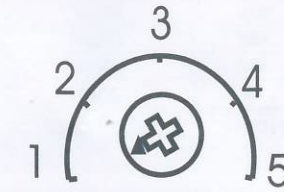

Please see the diagram to adjust the response time of the receiver. Usually, the time set shall be less than the time when the intruder crosses the guarding area.

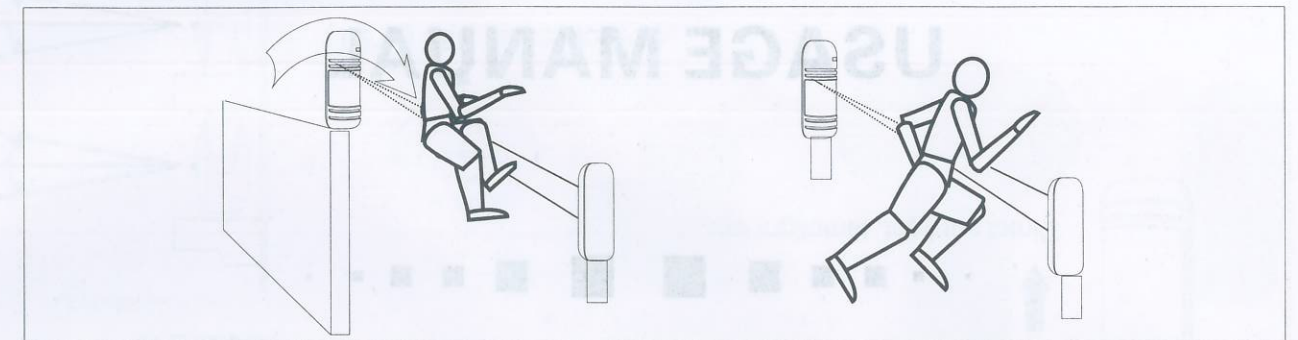

High speed:1

Fast running(6.9m/s):2

Fast walking(1.2m/s):3

Normal walking(0.7m/s):4

Slow walking(0.4m/s):5



VI. Physical test

Walking test is required after the setting, physical test in accordance to below diagram.

	State	Signal
Transmitter	Transmitting	The 2 indicators of green LED light up
Receiver	Guarding	GOOD LEVEL indicators light up
	Alarming	The red ALARM indicator light up

VII. Trouble checking

Fault	Cause	Solution
The LED of the transmitter doesn't light up	Power failure (open circuit, short-circuit, etc.)	Check the power wiring
The LED of the receiver doesn't light up	Power failure (open circuit, short-circuit, etc.)	Check the power wiring
The LED of the receiver doesn't light up when the light is blocked	1.By reflecting, or light from other sources enter the receiver 2.Both beams are not blocked at the same time 3.Response time is set too short	1.Remove the reflecting object or change the direction of beam 2. Block both beams at the same time 3.Prolong the response time
The receiver alarm indicator is on after the beam blocked, but there is no alarm signal output	1.Broken circuit or short-circuit of the wiring 2.Poor contact	1.Check the wiring and contact 2.Connect the cable again
The alarm indicator of the receiver is on constantly	1.The beam doesn't match closely 2.There is obstacle presents between the transmitter and the receiver 3.The cover is polluted.	1.Re-adjust the beam 2.Remove the obstacle 3.Clear the cover
Regular false alarm	1.Improper wiring 2.The supply voltage does not reach 12V or higher 3.The potential obstacle appears to block the beams due to the effect of wind and rain 4.The installation base unstable 5.The beam coincidence accuracy is inadequate 6.Beams blocked by other moving objects 7.Response time too short 8.Level 5 LED does not light up before the cover is put on	1.Check the wiring 2.Check the supply power 3.Remove the obstacle or change the location 4.Select a site with a stable base 5.Re-adjust the optical axis 6.Adjust the shade time or change the installation site 7.Re-adjust the response time 8.Re-adjust the optical axis, and make the signal reception reaches its top

VIII. Technical parameters:

Model		50L	100L	150L	200L	250L
Alert distance	Outdoor	50m	100m	150m	200m	250m
	Indoor	150m	300m	450m	600m	750m
No. of beams	4 beams					
Detection mode	4 beams blocked simultaneous					
Optical source	Infrared digital pulse beam					
Response speed	35-700msec adjustable					
Alarm output	Relay contact output:NO or NC Contact rating:AC/DC30V 0.5Amax					
Power supply *	DC12-24V AC11-18V P≤1.6W					
Power consumption	95mA	100mA	100mA	100mA	105mA	
Operation temperature & humidity	-25 _i -5 _ϕ 5%-95%RH(relative humidity)					
Dimensions	Refer to its diagram					
Tamper output	Contact output:NC Contact rating:AC/DC24V 0.5Amax					
Optical axis adjustment(H)	180° (±90°)					
Optical axis adjustment(V)	20° (±10°)					
Viewfinder	Window style					
Protection against dew, frost	Calefaction housing (optional)					
Material	PC resin					
Gross	2450g					

IX. Recommended installation guide & physical appearance and dimension

Recommended installation

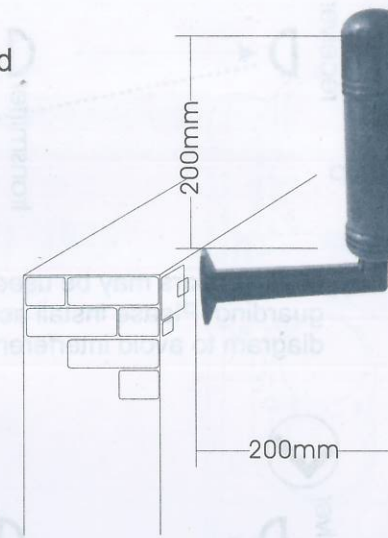

Installation bracket

T-shaped bracket
T-100
100×120mm

T-200
200×120mm

I-shaped bracket
I-100
100mm

I-200
200mm

L-shaped bracket
80×75mm

Dimensions

